

The M67 is a transistorized microphone mixer/remote amplifier specifically designed for professional applications. The excellent performance and versatility of this complete, compact console make it an ideal choice for studio, remote, or original sound reinforcement use, and as an "add-on" mixer for expanding existing facilities. It is also ideally suited for use with tape recorders and VTR's to provide multiple microphone inputs.

The Model M67-2E Professional Microphone Mixer is similar to Model M67 except that it is designed to be connected to a 216-264 volt AC power line.

All information on the data sheet for the Model M67 applies, except for those references to AC operating voltage and power-line cord.

Features include:

- Wide, flat frequency response and low distortion at up to +18 dbm output.
- Extremely low noise and RF susceptibility.
- Four low impedance balanced-line microphone inputs with individual gain controls. Mumetal shielding on input transformers.
- Line input switchable for 600-ohms terminating, or bridging.
- Outputs, 600-ohm line and low impedance microphone level. Outputs may be used simultaneously.
- VU meter calibrated for +4 and +10 dbm with range switch. Illuminated with AC operation.
- Meter isolated from DC on line. Line output transformer unaffected by up to 100 ma DC.
- AC or battery operation (with accessory battery pack). Noiseless automatic switch-over to battery in event of AC line failure. Battery test provision.
- Low frequency roll-off switch on each channel.
- Two-level headphone monitor provision designed to accommodate 600 to 2,000 ohm headphones. Any headphones from 8 ohms to crystal may be used.
- Direct mix bus input for stacking units.
- Line output terminals phase indicated. All connections phased.
- Compact, lightweight.

Guarantee: This Shure product is guaranteed in normal use to be free from electrical and mechanical defects for a period of one year from the date of purchase. Please retain proof of purchase date. This guarantee includes all parts and labor.

Shipping Instructions: Carefully repack the unit and return it prepaid to the factory. If outside the United States, return the unit to your dealer or Authorized Shure Service Center for repair. The unit will be returned to you prepaid.

SPECIFICATIONS

PERFORMANCE

Frequency Response: ± 2 db from 30 to 20,000 Hz.

Gain: (Outputs terminated; line 600 ohms, microphone 150 ohms). Gain will decrease a maximum of 5 db with nearly exhausted battery.

Input	Output	
	Line	Microphone
Low Impedance Microphone (150 ohms)	90 db	30 db
Line, Bridging or Terminating	40 db	-20 db

Noise: Equivalent input noise: -129 dbV (low impedance microphone, 150 ohms -300 to 20,000 Hz.) into 600-ohm load, at full gain.

Equivalent input hum and noise: -125 dbV (low impedance microphone, 150 ohms -20-20,000 Hz.) into 600-ohm load, at full gain.

Distortion: Under 1% T.H.D. from 20 to 20,000 Hz. at +10 dbm out (0.5% Typical).

Control Interaction: Under 1 1/2 db with any control combination.

INPUTS

Input	Impedance		Input Clipping
	Designed For Use With	Actual (Internal)	
Microphone	25-600 ohms	800 ohms	-30 dbV (150 ohms)
Line, Bridging	Less than 10 K ohms	66 K ohms	Greater than +22 dbV
Line, Terminated	600 ohms	600 ohms	Greater than +24 dbm

Minimum Common Mode Rejection:

100 db with microphone input of 10 volts at 100 Hz.

OUTPUTS

Output	Impedance		Output Clipping Level
	Designed For Use With	Actual (Internal)	
Microphone	Any low impedance microphone input.	0.5 Ohms	6 mv, -44 dbV
Line	600-Ohm*	140 Ohms	+18 dbm

*Other line impedances may be used; however, the VU meter is calibrated for 600-Ohm line termination. See "VU Meter" Section on Page 3.

Headphone Output: See "Headphone" Section on Page 3.

Temperature Range:

Operating: 0°F to 135°F (-17.8°C to 57°C)
Storage: -20°F to 160°F (-29°C to 71°C)

Overall Dimensions: See Figure "A"

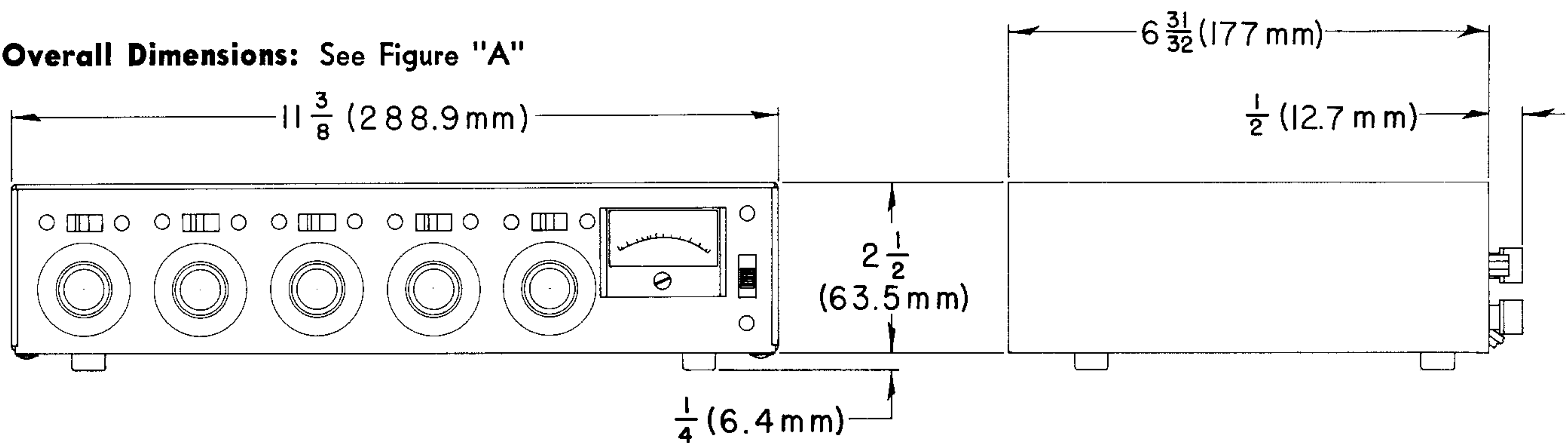

OVERALL DIMENSIONS — FIGURE A

Overload and Shorting Protection:

Shorting the outputs, even for prolonged periods, will produce no damage.

Microphone inputs will not be damaged by signals of up to 3 volts (100 times clipping level).

Operating Voltage:

MODEL M67:

AC Operation: 120 volts, $\pm 10\%$ at 50 to 60 Hz.

DC Operation: 30 volts, 6 ma. maximum drain for +10 dbm output.

MODEL M67-2E:

AC Operation: 240 volts, $\pm 10\%$ at 50 to 60 Hz.

DC Operation: 30 volts, 6 ma. maximum drain for +10 dbm output.

The Model M67-2E is supplied with a three-conductor power-line cord, but no plug. The power-line cord plug should be installed by a qualified person. The brown lead should be connected to the "live" or "hot" terminal of the plug, and the blue lead to the neutral terminal of the plug. The green/yellow lead is the grounding conductor and should be connected to the ground or earth terminal of the plug.

Weight: 4 lbs., 13 oz.

CONTROLS, CONNECTIONS

INPUTS AND OPERATIONS

Microphone:

The four microphone inputs are professional female three-pin audio connectors located on the rear panel and designated "Mic. 1" through "Mic. 4." †

Inputs are balanced (internal transformer, mumetal shielded) and connections are Pins 2 and 3 "hot," Pin 1 "ground."

For microphone operation, the switches labeled "Mic. 1/Tone Osc." and "Mic. 4/Line" must be in the "Mic. 1" or "Mic. 4" position.

For impedance and clipping level see Table under Input Specifications.

Line:

The "Mic. 4" connector is also used as the Line Input Connector by switching the "Mic. 4/Line" switch to "Line."

Provision is made for either 600-ohm line termination or bridging, the choice being made by the appropriate position of the "Bridge/Terminate" switch above the input connector.

Either configuration is balanced and connections are

† Designed to mate with Cannon XL series, Switchcraft A3 (Q.G.) series or equivalent connector.

Pins 2 and 3 "hot" and Pin 1 "ground."

Impedances and operating signal levels are shown in the "Input Specifications" Section.

OUTPUTS

Microphone:

The microphone level output is a professional male three-pin audio connector located on the rear panel with the designation "Mic. Output." † It is used for feeding a low impedance microphone line or the low impedance microphone input of an associated piece of equipment. This is a balanced output with Pin 1 "ground." Pins 2 and 3 are "hot," and are in phase with the corresponding pins of the input connectors.

Line:

The line output (binding posts) appears on the rear panel and is designated "Line Out." These terminals are numbered "3" and "2" and are in phase with correspondingly numbered pins in the input connectors. The adjacent ground terminal corresponds to Pin 1. While the line output may be used to drive lines of various impedances, the VU meter is calibrated for use with a 600-ohm terminated line.

The line output transformer will operate properly with up to 100 ma. DC flowing through the line. This feature allows use of ordinary "dialed-up" telephone lines with DC across them. (Since a slight increase in distortion may occur at high output levels with maximum DC current, operation at +4 dbm is recommended for this use.)

NOTE: The microphone and line outputs may be used simultaneously if desired, to provide an isolated PA feed or to drive different pieces of equipment.

CONTROLS

Individual Input Gain Controls:

Front panel controls designated "Mic. 1" through "Mic. 4" are the individual gain controls for correspondingly numbered inputs. Note that the input connectors are located on the rear panel directly behind their corresponding numbered control.

Control "Mic. 1" serves an additional function as the individual level control for the tone oscillator when the "Mic. 1/Tone Osc." switch is in the "Tone Osc." position.

Control "Mic. 4" also serves as the individual gain control for the line input when the "Mic. 4/Line" switch is in the "Line" position.

NOTE: For best signal-to-noise ratio, the individual input controls should be operated at as high a setting as possible, consistent with maintaining adequate control range.

Master Gain Control:

The front panel control designated "Master" is the master gain control and controls the overall output level of all the mixed sources (including signals which may be applied to the "Mix Bus" input).

VU METER

Range:

The VU meter is factory calibrated for use with a 600-ohm terminated line. The "VU Range Switch" above the master gain control selects either a +4 or +10 dbm output at 0 VU meter indication. (This switch changes the meter indication, and does not change the actual output level.) Microphone output levels are 60 db below line output.

The +4 range is recommended for normal use to provide 14 db margin from operating level to clipping level.

The VU meter is calibrated with no load on the headphone output. Low impedance (under 250 ohms) phones may have some loading effect and alter the VU calibrations slightly. If the use of such phones appears to be normal, (or if other than a 600-ohm terminated line is used) it may be desirable to recalibrate the VU meter by means of the "VU Cal." control (see Figure D.) (Range of this control is approximately ± 2 db.)

Illumination:

The VU meter is illuminated by two No. 47 lamps operating well under the normal ratings for a life expectancy of greater than 10,000 hours. The lamps are used only with AC operation. Consequently, when a battery supply is used as a safety stand-by, the illumination serves as a visual alarm if the AC is interrupted and the unit has switched to battery.

For lamp replacement instructions see Figure E.

DC Isolation:

The VU meter is connected on the primary side of the output transformer to assure protection from any DC level on the telephone line. (See OUTPUTS, LINE)

tone OSCILLATOR

A built-in tone oscillator is provided for line test and level checks. The tone oscillator is activated by setting the "Mic. 1/Tone Osc." switch (rear panel) to "Tone Osc." and may then be controlled in level by control "Mic. 1/Tone Osc." (on the front panel). The frequency is approximately 700 Hz. and the signal will appear on both line and microphone outputs as well as the headphone and mix bus connectors.

The oscillator should be switched off ("Mic. 1" position) when not actually in use.

LO-CUT FILTERS

These filters are activated by the switch above each of the individual channel level controls, and may be used individually with each control as needed. The typical response function is shown in Figure B. The "Mic. 4/Line" filter will operate with either microphone or line input.

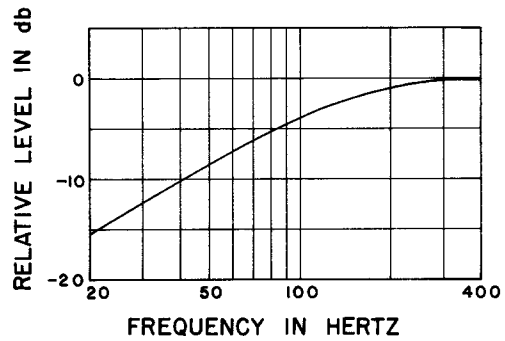

TYPICAL LOW-CUT FILTER ACTION
FIGURE B

HEADPHONES

The headphone output appears on the rear panel and is designated "Headphones." A two-circuit phone jack is used to provide a choice of level for different headphone impedances. Normally, a single circuit plug should be used. If inserted only partially (to the first detent), the available voltage is approximately .18 volts into 1,000 ohms with +4 dbm out of the "Line Out" terminals. With the same operating conditions the second position will provide approximately .38 volts. These voltages are selected for normal operation with 600-ohm to 2,000-ohm headphones. Other headphone impedances may be used, but with a variation in the monitor level and the possibility of a slight amount of VU meter loading with very low impedance phones. (Maximum change is 0.5 db with headphone jack shorted.)

If stereo phones are used, the two-circuit plug may be inserted completely (to second position) and output will appear in both phones.

The "Tip" connection of the headphone plug will be in phase with Pin 3 of all input and output connectors, and with the tip of the mix jack.

MIX BUS

Direct access to the mixing bus is provided through the "Mix Bus" jack (phono type) on the rear panel. This provision is made primarily to facilitate "stacking" (or multing) of M67's to achieve additional input capacity without losing any inputs.

With two M67's, for example, the two mixing buses are directly connected, providing two independent masters and two isolated line amplifiers with eight individually controlled inputs. Since the buses are directly paralleled, a 6 db level drop will occur, but the VU meter indication will still be correct. Noise specifications are not adversely affected by this interconnection.

The input clipping level to the mixing bus is 0.2 volts through 3.5 K ohms. The gain from "mix bus" input to line output is 70 db, and from 150 ohm microphone to "mix bus" is 20 db.

To facilitate stacking, a hardware and cable kit is available as Shure Accessory Model A68S.

If other use of this provision is contemplated, it should be remembered that the "mix bus" terminal is connected directly to the mixing bus and operates at 3.5 K ohms impedance, hence connecting devices should have at least 3.5 K ohms internal impedance.

BATTERY OPERATION

Battery Supply

The M67 is designed so that it may be operated with an external battery or well filtered DC supply providing 30 Volts DC. Current drain is under 6 ma. at +10 dbm output level.

The DC input terminals are located adjacent to the power cord on the rear panel and are designated "30 Volts DC" "+", and "-".

The use of battery supplies designed for the M67 (see Accessory List) is recommended both for convenience in connecting and mounting and to permit use of the automatic power change-over feature.

Automatic Power Change-Over

When used with Shure accessory power supplies, the M67 may be operated from the AC power line with the battery supply connected. In this configuration, the unit will automatically switch to battery operation should AC voltage fall below a suitable level. This change-over is completely automatic, instantaneous, and completely noiseless. Should line power fail completely, the VU meter lamps will extinguish, providing a visual indication of the line failure. If use of a 30-volt DC supply other than Shure Battery Supplies is desired, the automatic change-over feature may be retained by connecting a suitable silicon diode (Shure RKC21) in series with the positive lead. The cathode (band) end connects to the +30-Volt DC terminal.

Battery Check

Battery condition may be determined by use of the "Battery Check" position of the main power switch adjacent to the VU meter. This check must be made with the AC line cord disconnected. The check procedure is as follows:

With the AC line cord disconnected, leave power switch in "ON" position for at least ten seconds (to discharge filter capacitors), then move switch up to "Battery Check." Observe reading on VU meter. A new battery will give about a +2VU indication. Battery condition is good if meter indication is above 0 VU (red end of scale). 0 VU or below indicates that battery must be replaced for proper operation.

For best performance on battery operation at temperatures below 40° F., change batteries when Battery Check meter reading is 1.0 VU or lower.

NOTE: This check interrupts power to the amplifiers, and therefore, should be made only when the unit is not in operation.

DC Power Take-Off

With AC operation, the "30-Volt DC" terminals are energized with polarity shown and may be used to power up to two additional M67's or other 30-volt DC low drain accessories.

ACCESSORIES

A67B Battery Supply

This unit is designed to power the M67 at full rated output. Battery life is approximately 70 hrs at +10 dbm and 85 hrs at +4 dbm output at 4 hours use per day. See temperature note below.

It may be used either as the sole power source or as a stand-by safety during AC operation, providing automatic, noiseless switchover in case of AC failure. The housing is designed to attach to the M67 as shown in Figure C, and is attached by removing one of the M67 cover screws, positioning the battery supply over the hole, and fastening the two together with the screw.

The battery complement is three Eveready 216's or equivalent 9-volt batteries.

Earlier models of the A67B had a battery complement of three Burgess U20's, Eveready 413's or equivalent 30-volt battery.

NOTE: Due to changes in the operating characteristics of carbon-zinc batteries at low temperatures, the useful operating life will be noticeably shorter at lower than normal room temperatures. See Battery Check Instructions.

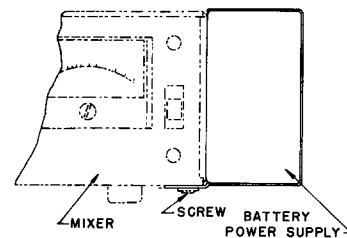

A67B INSTALLATION
FIGURE C

A67H Handle/Tilt Stand

The Model A67H is designed to provide a convenient means for tilting the M67 to permit better panel visibility and greater ease of operation. In the locked position the front panel is elevated 20°. In the free position, the A67H serves as a rugged carrying handle.

A68P Phono-Preamplifier

The A68P is a monaural pre-amp which may be used to convert the bridging line input of the M67 for use as an equalized phono input. It provides both equalization and preamplification, and is powered from the 30-volt DC power take-off provision. (The A68P is supplied with a phono plug which must be replaced with a Cannon XL3-12 type connector. Pin 3 center conductor, pins 2 and 1 shield)

A68S Stacking Kit

This accessory consists of brackets for vertical stacking of two M67's, and the interconnecting cable for the mix bus connections.

A68R Rack Panel Kit

This kit consists of a 19"x3 1/2" precut rack panel and necessary hardware for rack mounting of the M67 with its cover in place.

A68L Locking Panel

This panel fits within the front hood of the M67 cover and locks in place to prevent tampering with the front panel controls.

AC60 Attache Carrying Case

This case is compartmentalized and foam lined for an M67 and accessories.

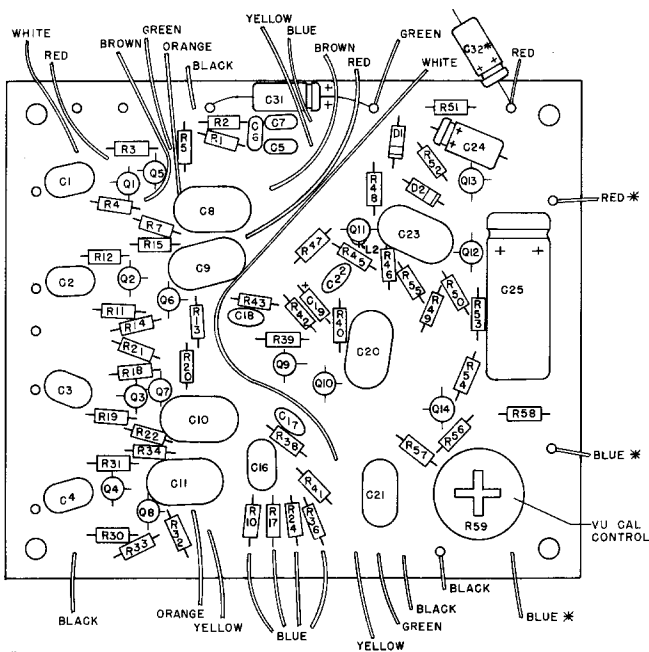

* IT IS NECESSARY TO DISCONNECT, AT ONE END ONLY, THE THREE WIRES & CAPACITOR MARKED * TO ALLOW BOARD TO TILT 90° UP FOR SERVICING.

PRINTED CIRCUIT BOARD ASSEMBLY

FIGURE D

PARTS LIST			
ITEM	SHURE KIT NO.	QUANTITY IN KIT	DESCRIPTION
D1,D2,D7,D8	RKC21	4	DIODE, SILICON, IN4002 OR EQUIVALENT.
D3,D4,D5,D6	RKC19	4	DIODE, GERMANIUM, IN48 OR IN50.
PL1,PL2	RKC7	4	LAMP, PILOT #47, 6.3 V.A.C.
M1	RKC5	1	METER, D.C., 190 MICROAMPERE VU MOVEMENT.
Q5-Q8,Q10,Q11*	RKC9	4	NPN TRANSISTOR, 86A349, SILICON, SELECTED HIGH GAIN, LOW NOISE SIMILAR TO MOTOROLA 2N3058 OR TI 2N3711.*
Q1-Q4, Q9*	RKC89	4	NPN TRANSISTOR, 86A350, SILICON, SELECTED HIGH GAIN, LOW NOISE SIMILAR TO MOTOROLA 2N5210.*
Q12	RKC12	1	NPN TRANSISTOR, 86A336, SILICON, TEXAS INSTRUMENT T1597.
Q13**	RKC65	1	NPN TRANSISTOR, 86A334, SILICON, TEXAS INSTRUMENT T1592.**
Q14**	RKC66	1	PNP TRANSISTOR, 86A335, SILICON, TEXAS INSTRUMENT T1593.**
R9,R16,R23,R35,R44	RKC3	1	POTENTIOMETER 50 K, AUDIO TAPER.
R59	RKC17	2	RHEOSTAT, 5.0 K ± 20%, LINEAR.
S1	RKC11	1	SWITCH, SLIDE, 3PDT.
S9	RKC64	1	SWITCH, SLIDE, DP3T.
S2-S8	RKC10	4	SWITCH, SLIDE, DPDT.
T1-T4	RKC8	1	TRANSFORMER AND SHIELD ASSEMBLY
T5	RKC18	1	TRANSFORMER, OUTPUT, 600 OHM TO 600 OHM, AND MIC.
T6	RKC15	1	TRANSFORMER, POWER, (M67).
	RKC16	1	TRANSFORMER, POWER, (M67-2E).
LH-1	RKC13	1	LAMPHOLDER AND BRACKET.
LH-2	RKC63	1	LAMPHOLDER AND BRACKET (GROUNDED).
PC-1	RKC14	1	PRINTED CIRCUIT BOARD ASSEMBLY.
CP1	RKC-2	1	POWER CORD AND PLUG ASSEMBLY (M67).
	RKC-1	1	POWER CORD (M67-2E).
NOT SHOWN	RKC20	1	CHASSIS COVER.
K1-K4	RKC6	1	BLACK KNOB
K5	RKC57	1	GRAY KNOB

* TO INSURE LOW NOISE FIGURE, PURCHASE REPLACEMENTS FOR Q1-Q11 FROM SHURE BROTHERS, INCORPORATED.
 ** FOR REPLACEMENT, PURCHASE Q13 AND Q14 AS MATCHED PAIR T1592M-T1593M.

LAMP REPLACEMENT

1. DISCONNECT A.C. CORD.
2. REMOVE 4 PHILLIPS HEAD SCREWS RETAINING COVER - ONE ON FRONT, ONE ON BACK, TWO ON BOTTOM.
3. REMOVE COVER.
4. REMOVE SPRING RETAINER ON TOP OF VU METER. NOTE METHOD OF ASSEMBLY - EASILY REMOVED BY PUSHING DOWN SPRING AT ONE END ADJACENT TO ALUMINUM BRACKET.
5. GENTLY PUSH VU METER FROM FRONT AND LIFT UP CLEAR OF CHASSIS.
6. BRACKETS MAY FALL OUT. NOTE THEIR POSITION IN CUT-OUT. BRACKETS ARE INTERCHANGEABLE.
7. REMOVE SCREWS RETAINING LAMP SOCKETS FROM UNDERSIDE OF CHASSIS. SOCKETS MAY NOW BE PUSHED CLEAR OF CHASSIS AND NEW #47 LAMPS REPLACED. IT IS ADVISABLE TO REPLACE BOTH LAMPS WHEN 1 BURNS OUT.
8. REPLACE LAMP SOCKETS AND LOOSELY FASTEN SCREWS.
9. PLACE 2 VU METER BRACKETS IN CUT-OUT, PUSHING THEM FIRMLY AGAINST SIDES OF CUT-OUT.
10. SLIDE VU METER INTO CUT-OUT. SHOULD LAMPS BE IN THE WAY, MOVE THEM. VU METER SHOULD FIT EASILY INTO CUT-OUT IF POSITIONED PROPERLY. DO NOT FORCE.
11. HOLDING VU METER FIRMLY AGAINST BACK SIDE OF CHASSIS FRONT PANEL, SQUEEZE BRACKETS AGAINST METER BODY. LOOP ONE END OF SPRING CLIP IN NOTCH OF INSIDE BRACKET. END OF SPRING CLIP POINTS UP, NOT DOWN. HOOK SPRING CLIP OVER PLASTIC RETAINER ON METER, AND FORCE OTHER END OF SPRING CLIP DOWN UNTIL IT SNAPS IN OUTSIDE BRACKET.
12. CHECK POSITIONING OF LAMPS, AND TIGHTEN THEIR 2 MOUNTING SCREWS.
13. REPLACE COVER.

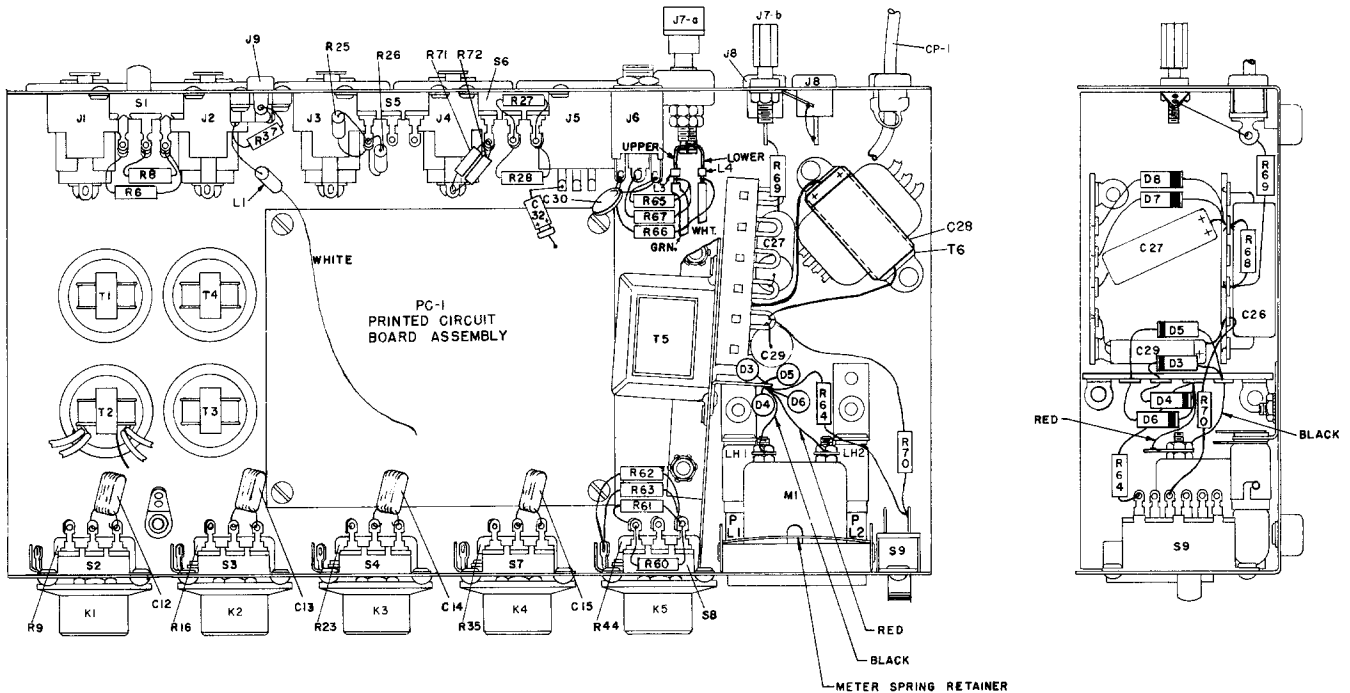

PARTS PLACEMENT

FIGURE E

NOTES:
 1) ALL FIXED RESISTORS IN OHMS, 1/4 WATT COMPOSITION TYPE, ±10%, UNLESS OTHERWISE SPECIFIED. K=1000, M=1,000,000.
 2) ALL CAPACITORS IN MFD, 50 VOLTS OR GREATER, UNLESS OTHERWISE SPECIFIED.
 3) ALL GREEN AND YELLOW LEADS ATTACHED TO INPUT CONNECTORS AND TO SWITCHES FOR CHANNEL 4 ARE TO BE TWISTED PAIRS.

○ DENOTES A.C. VOLTAGES
 ○ DENOTES D.C. VOLTAGES

ALL VOLTAGES MEASURED WITH HIGH IMPEDANCE VTVM. WITH A.C. LINE=120VAC (240VAC. FOR M67-2E) D.C. VOLTAGES MEASURED WITH NO INPUT SIGNAL. ALL CONTROLS C.C.W.. A.C. VOLTAGES MEASURED WITH TO A MICROPHONE CHANNEL, ONE INPUT CHANNEL AND MASTER SET FULLY C.W., WITH OUTPUT TERMINATED IN 600 OHMS.

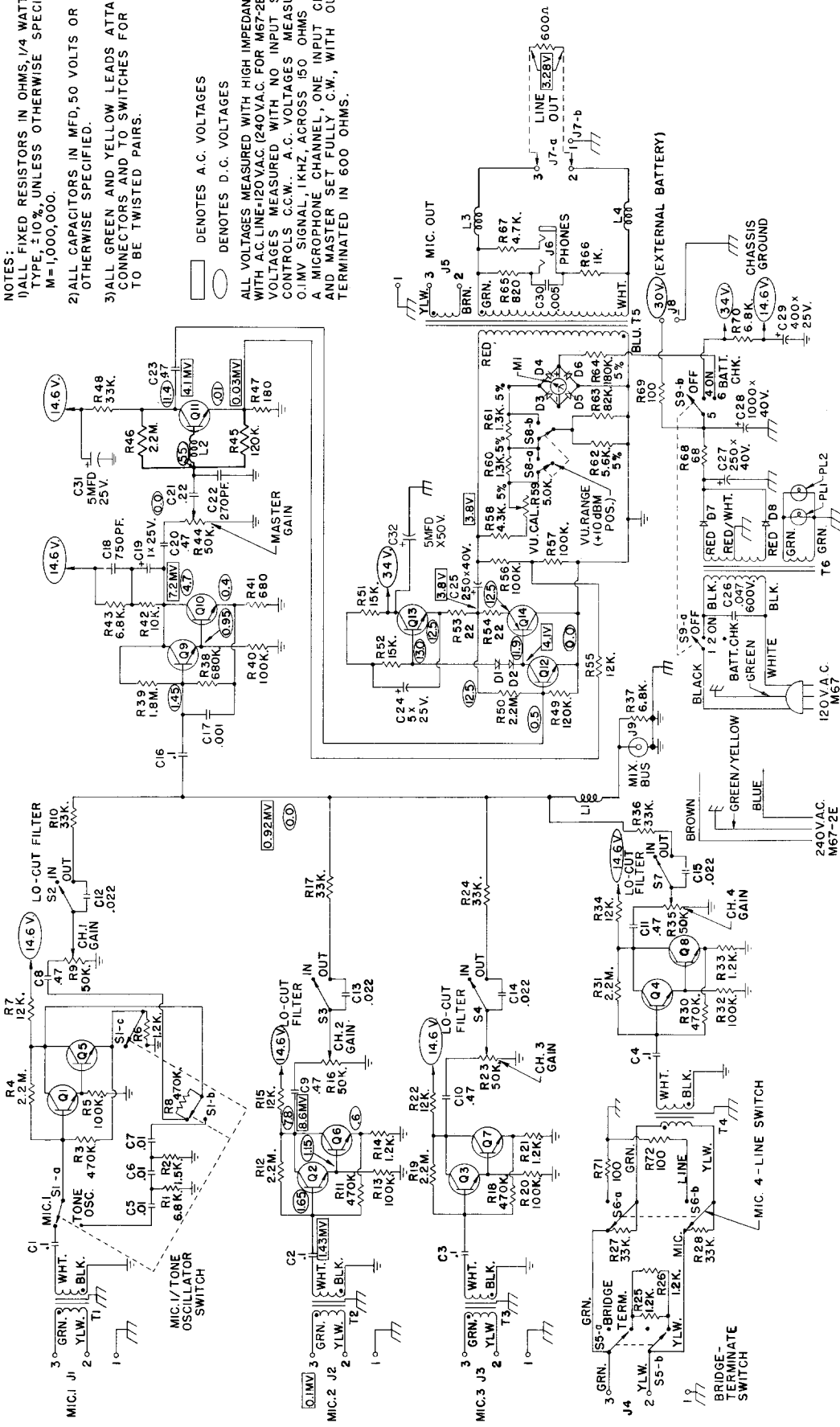

MODELS M67 AND M67-2E PROFESSIONAL MICROPHONE MIXERS CIRCUIT DIAGRAM